



*Make your Contribution  
to the Nanotechnology  
Revolution*

## **Nova 600 NanoLab DualBeam™-SEM/FIB for Nanoscale Prototyping, Machining, Characterization, and Analysis of Structures below 100 nm**

The Nova NanoLab brings new capabilities and flexibility to researchers and developers needing to create, modify, and characterize complex structures below 100 nanometers. It combines ultra-high resolution field emission scanning electron microscopy (SEM) and precise focused ion beam (FIB) etch and deposition to complement your existing Nanotechnology laboratory tools and extend your applications range for nanoscale prototyping, machining, 2D and 3D-characterization, and analysis. Setting the Nova NanoLab apart from other lab systems are its integrated 3D-characterization, nano-machining and nano-analysis capabilities. The Nova NanoLab is designed to be just that: a complete nanotechnology laboratory in one tool.

Comprehensive beam chemistries for deposition and etch, and automation enable creation of structures such as:

- nanotube-based nano-structure assembly;
- nano-bridge creation;
- photonic array prototyping;
- laser prototyping;
- nano-stamping;
- AFM tip modification;
- MEMS modification,

Nova NanoLab enables characterization of these structures via several methods, among them slice and view for 3D-reconstruction, ultra-high resolution in-lens backscattered electron imaging for phase contrast characterization, secondary ion imaging for grain contrast, SPI- simultaneous patterning and imaging mode for real-time imaging feedback on the milling process, and STEM for sub-1 nm characterization. Add nano-analysis capabilities such as EDS and EBSD, and you have a powerful nanotechnology solution that enables you to make your contribution in this growing science.

- *A complete nanotechnology lab in a single tool, enabling top-down machining or deposition and ultra-high resolution 3D-characterization of nano-structures*
- *Complements your existing tool set by extending the range of applications that you can handle in your lab*
- *Versatile beam chemistries provide speed, precision, and control for selective etch and metallic, insulator, and organic material deposition*
- *Automation of prototyping and machining processes assures accurate and reproducible results.*
- *4k x 4k pixel digital pattern generation enables creation of more complex 3D shapes and structures*
- *SPI- simultaneous patterning and imaging provides real-time process monitoring for enhanced control*
- *DualBeam™ geometry is designed to provide optimal ion and electron milling and imaging resolution at the beam coincident point*

## Nova 600 NanoLab essential specifications

### Tools for Nano-characterization:

#### Electron Optics:

- High-resolution Field Emission-SEM column, with monopole magnetic immersion final lens, Schottky thermal field emitter, 60 degree objective lens geometry and heated objective apertures.
- Source lifetime 12 months guaranteed
- Resolution @ optimum WD
  - 1.1 nm @ 15 kV (TLD-SE)
  - 2.5 nm @ 1 kV (TLD-SE)
  - 3.5 nm @ 500V TLD-SE
  - 5.5 nm @ 500 V TLD-BSE
- Resolution @ beam coincidence point:
  - 1.0 nm @ 30 kV STEM
  - 1.5 nm @ 15 kV (TLD-SE)
  - 2.0 nm @ 5 kV (TLD-SE)
- Max. Horizontal field width: 3.0 mm at beam coincidence point (corresponds to 35x minimum magnification in quad view)
- Accelerating voltage: 200 V – 30 kV
- Probe current: <= 20 nA in 21 steps

#### Detectors:

- In-lens SE detector (TLD-SE)\*
- In-lens BSE detector (TLD-BSE)\*
- Everhardt Thornley SED\*
- IR-CCD\*
- TV rate solid-state BSED
- Direct Ion Detector (CDEM)
- STEM detector

\* standard

#### Digital image processor:

- Dwell: 50 ns - 1 ms
- 11 presets + photo + snapshot
- Up to 3584 x 3094 pixel resolution
- File type: TIFF (8 or 16 bit), BMP or JPEG
- Single frame or 4-quadrant image display
- 4 quadrants live
- 256 frame average or integration

#### Imaging software accessories (optional):

- Slice and View automation software for sequential milling and imaging
- 3D reconstruction software

### Tools for Nano-prototyping:

#### Ion Optics:

- Magnum™ ion column with Ga liquid metal ion source
- Source lifetime: 1500 hours guaranteed
- Resolution: 7 nm (5 nm achievable)
- Max. Horizontal field width: 2.5 mm at 5 kV and beams coincidence point (corresponds to 50x minimum magnification in quad view)
- Accelerating voltage: 5 – 30 kV
- Probe current: 1 pA – 20 nA in 15 steps
- Beam blanker standard – external control possible
- 15 position aperture strip

#### Fabrication and machining:

- Minimum deposited line width (Ion beam, Pt): 50 nm achievable
- Minimum deposited line width (Electron beam, Pt): 20 nm achievable

- Minimum etched line width (Si): <15 nm achievable
- Maximum hole aspect ratio (Si, 500 nm hole radius): 10:1
- Maximum hole aspect ratio (Si, 500 nm hole radius, XeF<sub>2</sub>, coaxial needle): 20:1
- Typical TEM sample prep membrane thickness: 50 - 100 nm (30 - 50 nm achievable)

#### Digital pattern generator:

- 4 k x 4 k resolution
- 1 M pixels addressable
- Min. dwell: 100 ns
- Max. dwell: 4 ms

#### Gas chemistry:

- “Zero-collision” GIS design concept
  - Individual gas injectors with separate injections systems reconfigurable in the future
  - 5 μm placing accuracy without user interaction
  - GIS control available for automation
- Up to 5 gas injectors for enhanced etch or deposition
- Gas chemistry options:
  - Platinum metal deposition
  - Tungsten metal deposition
  - Insulator deposition (SiO<sub>2</sub>)
  - Enhanced metal etch (Iodine)
  - Insulator Enhanced etch (XeF<sub>2</sub>)
  - Delineation etch
  - Selective Carbon Mill (SCM)
  - Carbon deposition
  - Empty crucibles for FEI-approved user supplied materials

**End-point detection:**

- By stage current graph (UI element)
- By real-time monitor (Ion-beam SE image-pattern overlay)
- By sequential or simultaneous patterning / imaging
- By SPI mode

**Charge neutralization:**

- By dedicated charge neutralizer for high current milling
- By e-beam scanning for low current milling

**Supporting software:**

- “Beam per quad” graphical user interface concept
- Patterns supported: lines, boxes, open boxes, polygons, circles, cross-section and cleaning cross-section
- Patterns based on current and imported image
- Directly imported BMP file for 3D milling

- File support for “minimum loop time”, beam tuning and independent overlaps
- AutoFIB automation software for multi-site sample milling requirements (optional)
- Auto TEM automation software for unattended TEM sample preparation (optional)

**System utilities:**

**Vacuum system:**

- 1x 240 l/s TMP oil-free
- 1x PVP oil-free
- 3x IGP (total for electron column and ion column)
- Chamber vacuum: <math>2.6 \times 10^{-6}</math> mbar
- Evacuation time (high vacuum): <math>< 5.0</math> mins

**Chamber:**

- 379 mm left to right
- 21 ports
- 5 mm E- and I-beam coincidence point = analytical WD
- Angle between electron and ion columns: 52°

**5-axis motorized stage:**

- Eucentric goniometer stage
- X = 150 mm
- Y = 150 mm
- Z = 10 mm
- Clearance = max. 55 mm to eucentric point
- T = -10° to + 60°
- R = n x 360°
- Minimum step: 100 nm
- Repeatability @ 0° tilt; 1 μm
- Repeatability @ 52° tilt; 2 μm

**System control:**

- 32-bit graphical user interface with Windows 2000, keyboard, optical mouse, multifunctional control panel and joystick (optional)
- Image display: 2 x18-inch LCD, SVGA 1280 x 1024

**Standard utilities:**

- Support computer
- Scripting interface for automation purposes

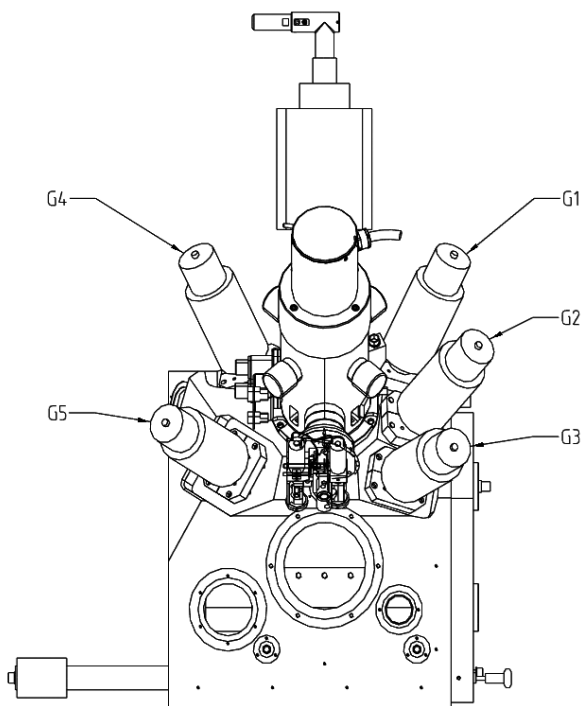

**GIS Injector port allocation**

**System options:**

- Electron Beam Blanker
- Omniprobe
- Specimen holder kit, TEM specimen holder kit
- 5" and 6" wafer holders
- S2 - 02 - 03 compliance

**Common 3<sup>rd</sup> party accessories:**

- EDX
- EBSP
- Prober module
- Nanomanipulator
- Lithography system

**Software accessories:**

- Web-enabled data archive software
- Image analysis software

**Consumables:**

- Replacement Ga-ion source
- Aperture strips for electron and ion column
- CDEM detector
- Gas chemistry crucibles

**Installation requirements:**

- Power: voltage 230 V (-6%, + 10%), Frequency 50 or 60 Hz (+/- 1%), Power consumption: < 3.0 KVA for basic microscope

- Environment: temperature 20 °C ± 3 °C, relative humidity below 80% RH, stray AC magnetic fields < 100nT a-synchronous, < 300 nT synchronous
- Door width: 120 cm
- Weight: column console 700 kg
- Compressed air 4-6 bar - clean, dry and oil-free
- System chiller
- Acoustics: < 60 dBC

**Documentation:**

- Operating instructions handbook
- On-line help

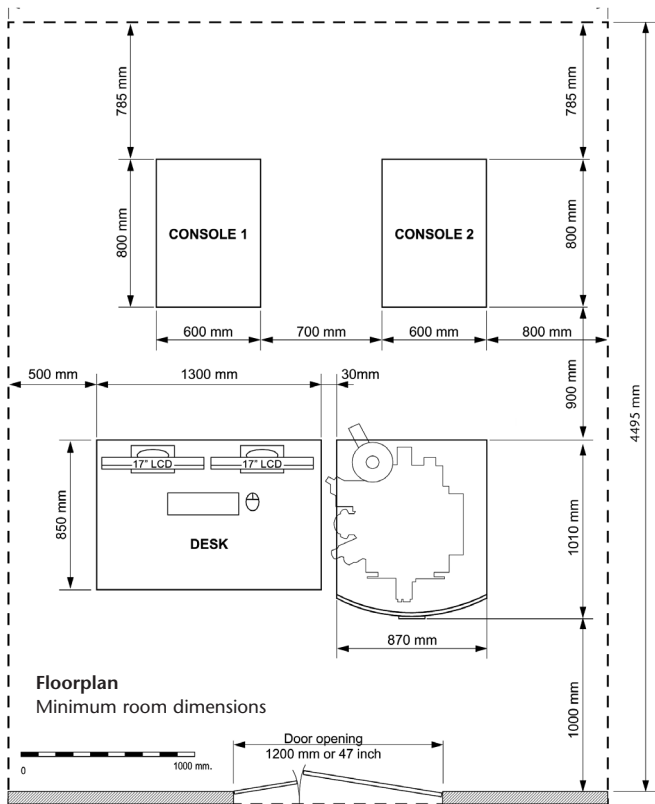

**FEI Company**

World Headquarters and  
 North American Sales  
 5350 NE Dawson Creek Drive  
 Hillsboro, OR 97124-5793 USA  
 Tel: +1 503 726 7500  
 Fax: +1 503 726 7509

European Sales  
 Tel: +31 40 27 66 768  
 Fax: +31 40 27 66 786

e-mail: sales@feico.com  
 www.feicompany.com

Asia-Pacific Sales  
 Tel: +65 351 7671  
 Fax: +65 354 0644

